

02-08 Dodge Ram 1500 Reg Cab, Quad Cab
03-08 Dodge Ram 2500/3500 Quad Cab

PARTS LIST

QTY	PARTS	QTY	PARTS	QTY	PARTS
8	3/8" Frame lock bolt	8	5/16" Flange Nut	4	Bracket #2 (2 notches)
8	3/8" Flange Nut	16	3/8" Flange Bolt (4 preinstalled on rail)	2	Bracket #4 (4 notches)
8	5/16" x 1.25 Hex Bolt	16	3/8" Rail-tab (4 preinstalled on rail)	8	Plastic Washers
8	5/16" Flat Washer	2	Bracket #1 (1 notch)		

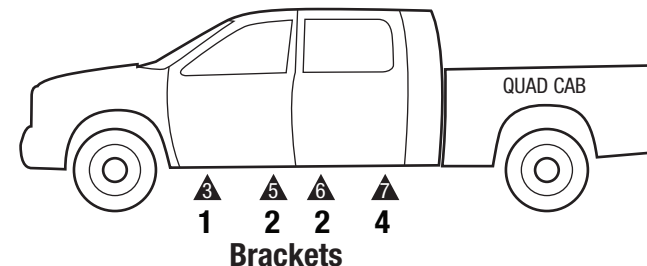

This installation sheet is for brackets with tube & rail system. Drop steps purchased separately.

BRACKET INSTALLATION

- 1) Remove contents from box and check for damaged parts. Verify all parts are present, making sure to read and understand instructions before install.
- 2) Locate (8) factory holes on inside body panel. Remove black tape covering holes 3, 5, 6, & 7 on Quad Cabs and holes 2, 3 & 4 on Reg Cabs. **Fig 1**
Install frame lock bolts into factory locations. **Fig 2** Thread square plastic washers on frame lock bolts to hold them in place. **Fig 2a**
- 3) QUAD CAB - Brackets that go in hole #3 will have (1) notch at the top of the bracket . Brackets that go in to holes #5 & #6 will have (2) notches at the top of the bracket. Bracket at hole #7 will have (4) notches at the top of the bracket. **Fig 3**

REG CAB - Brackets that go in hole #2 will have (1) notch at the top of the bracket . Brackets that go in to holes #3 & #4 will have (2) notches at the top.
- 4) Place brackets to thier specific locations on the frame lock bolts and fasten with 3/8" flange nut through hole "A". Hand tighten at this time . **Fig 3**
- 5) Push brackets firmly to inside body panel and mark the center of holes "B" to pinchweld with marker or paint pen.
- 6) Remove brackets from frame lock bolts to prepare pinchweld for drilling.
- 7) Drill a 3/8" hole into the points you have marked along the pinchweld.
- 8) Place brackets back to thier specific locations on the frame lock bolts and fasten with 3/8" flange nut and tighten. Place 5/6" hex bolt and flat washer through pinchweld and hole "B" of bracket and fasten with 5/16" flange nut and tighten. **Fig 3**
- 9) Repeat process for all brackets on passenger side.



***REQUIRES DRILLING**

(866) 476-6276 / (866) IRONCROSS
www.ironcrossautomotive.com
519 W. Dewey
Sapulpa, OK 74066
IRON CROSS AUTOMOTIVE INC. 2008

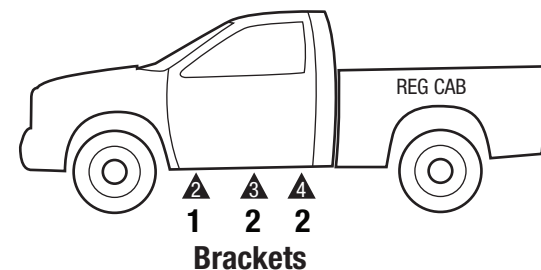

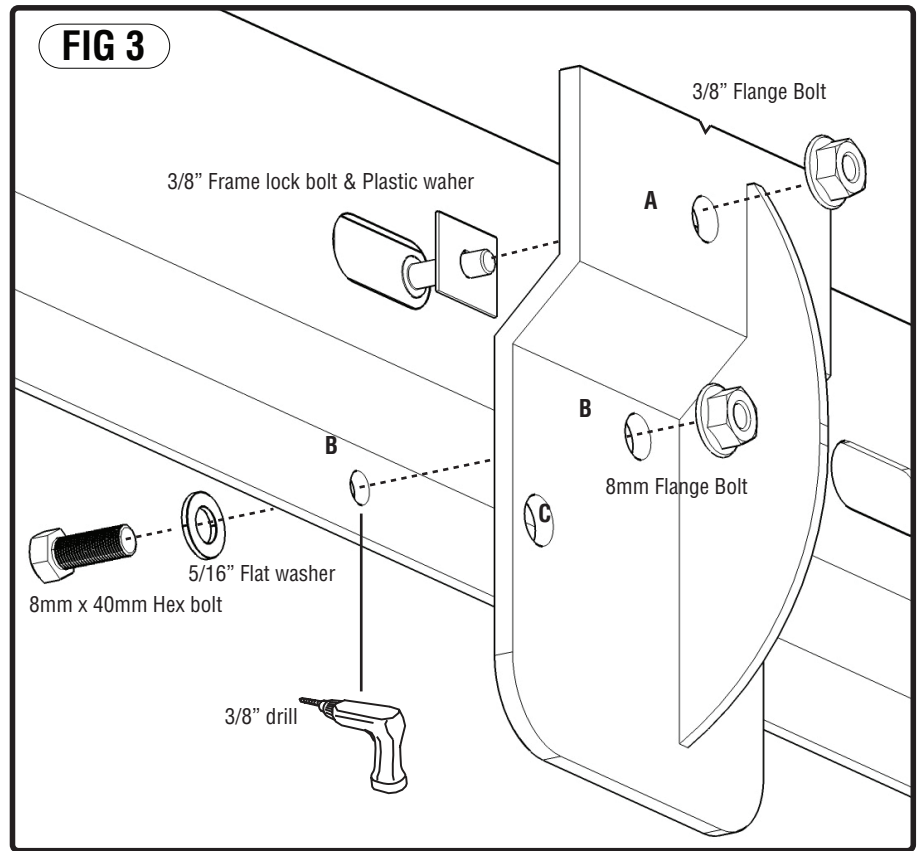
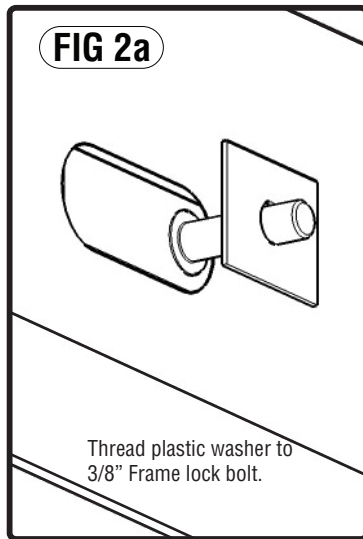
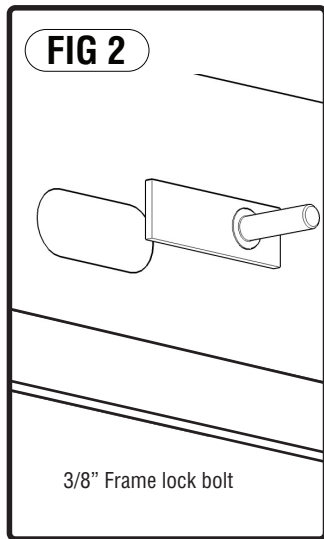
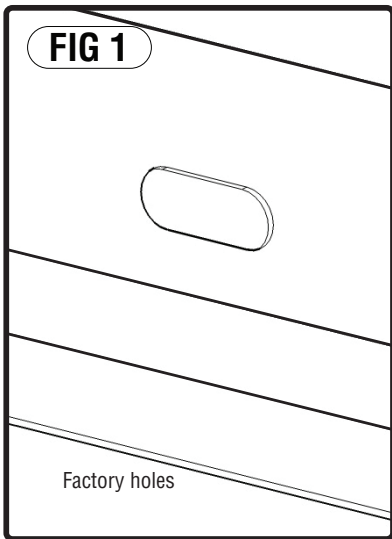

TUBE AND RAIL INSTALLATION CONTINUED ON PAGE 3

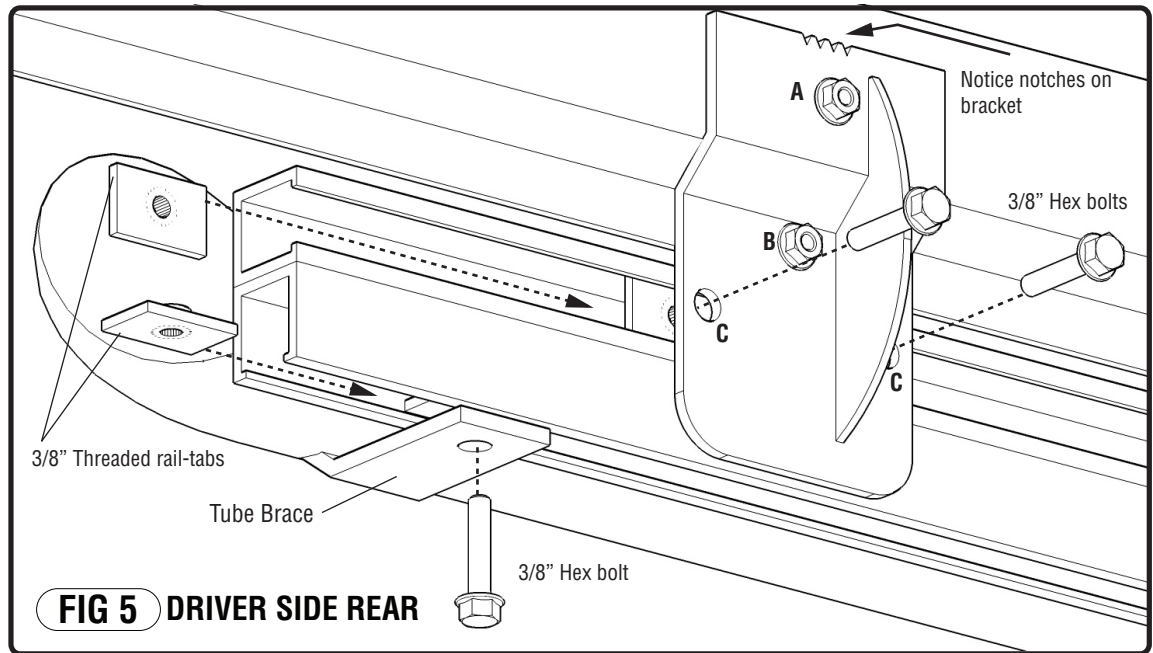
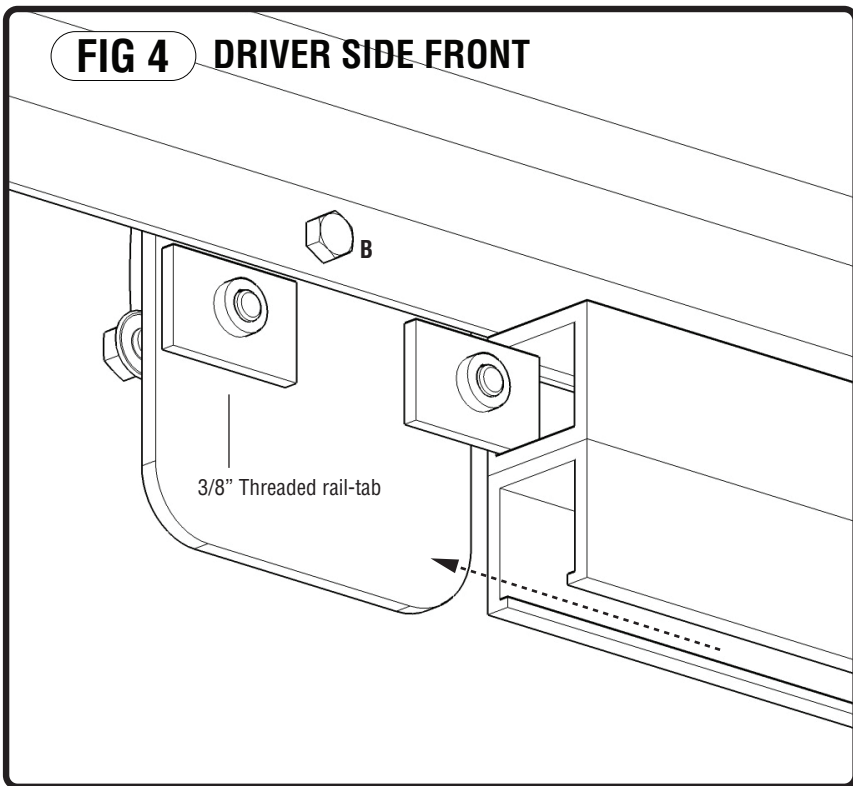

TUBE AND RAIL INSTALLATION (*Tubes and rails are not driver and passenger side specific. They fit both sides universally*)

- 1) Tube and rail come preassembled in box. Unassemble tube and rail before install. You may loosen hex bolt and slide rail from tube leaving hex bolt and rail tab on the tube brace.
- 2) Insert 3/8" hex bolt into hole "C" of front bracket and loosely thread rail-tab to bolt a few turns. Slide rail onto rail-tab. *Hand tighten at this time.* **Fig 5**
- 3) Slide middle bracket rail-tabs into rail and then attach rail to REAR bracket with 3/8" hex bolt and rail-tab. **Fig 5**
Hand tighten at this time.
- 4) Hold middle rail-tabs with fingers to thread 3/8" hex bolt through bracket into tab and tighten. *Hand tighten at this time.*
- 5) With 3/8" hex bolt and rail-tab fixed to TUBE BRACE, side onto bottom side of rail at near the rear bracket. **Fig 6**
- 6) Attach front of tube to rail by sliding rail-tab in to position and threading 3/8" hex bolt through tube brace. *Hand tighten at this time.*
- 7) Push up on rail when making final adjustments. **TIGHTEN ALL REMAINING BOLTS TO COMPLETE INSTALL. 40 FT LBS. MAX TORQ**

When making final adjustments, we recommend tube to be placed 2-3 inches from the rear of the FRONT wheel well.
Rail should be centered to tube. (1" past inner hole of tube or 5" from tube ends)

