

PARTS LIST

QTY	PARTS	QTY	PARTS	QTY	PARTS
16	8mmx30mm Bolts	2	Brackets Driver #1	8	Rail Tabs (4 pre-installed on rail)
16	5/16" Flat Washers	2	Brackets Driver #3	8	3/8" Hex Bolt (4 pre-installed on rail)
16	5/16" Lock Washers	2	Brackets Passenger #1		
		2	Brackets Passenger #3		

(866) 476-6276 / (866) IRONCROSS
www.ironcrossautomotive.com
519 W. Dewey
Sapulpa, OK 74066
IRON CROSS AUTOMOTIVE INC. 2008

Remove contents from box and check for damage parts. Verify all parts are present, making sure to read and understand instructions before beginning.

Brackets #1 Installation (positions 1&2) FIG 1&2

- 1) Distinguish driver and passenger side brackets. The brackets with a 90 degree side brace should be facing the front of the vehicle.
- 2) Bracket #1 will have (1) notch on side brace.
- 3) Align the #1 brackets at positions 1 & 2 to the 8mm threaded factory sidewall holes and install 8mm flat washers, lock washers and hex bolts. (Position 1 will use holes "A" & "C". Position 2 will use holes "B" and "C").
- 4) Tighten brackets at this time.

Brackets #3 Installation (positions 3&4) FIG 4

- 5) Bracket #3 will have (3) notches on the side brace.
- 6) Align the #3 brackets at positions 3 & 4 to the 8mm threaded factory sidewall holes "B" & "C" and install 8mm flat washer, lock washer and hex bolt.
- 7) Tighten brackets at this time.

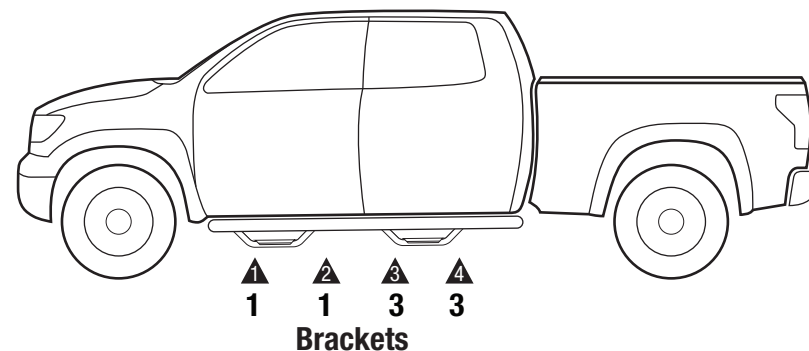

****Steps are a separate part number and sold separately.**

TUBE AND RAIL INSTALLATION (Tubes and rails are not driver and passenger side specific. They fit both sides universally)

- 1) Tube and rail come preassembled in box. Unassemble tube and rail before install. You may loosen hex bolt and slide rail from tube leaving hex bolt and rail tab on the tube brace.
- 2) Insert 3/8" hex bolt into hole "C" of front bracket and loosely thread rail-tab to bolt a few turns. Slide rail onto rail-tab. *Hand tighten at this time.* **Fig 5**
- 3) Slide middle bracket rail-tabs into rail and then attach rail to REAR bracket with 3/8" hex bolt and rail-tab. **Fig 5**
Hand tighten at this time.
- 4) Hold middle rail-tabs with fingers to thread 3/8" hex bolt through bracket into tab and tighten. *Hand tighten at this time.*
- 5) With 3/8" hex bolt and rail-tab fixed to TUBE BRACE, side onto bottom side of rail at near the rear bracket. **Fig 6**
- 6) Attach front of tube to rail by sliding rail-tab in to position and threading 3/8" hex bolt through tube brace. *Hand tighten at this time.*
- 7) Push up on rail when making final adjustments. **TIGHTEN ALL REMAINING BOLTS TO COMPLETE INSTALL. 40 FT LBS. MAX TORQ**

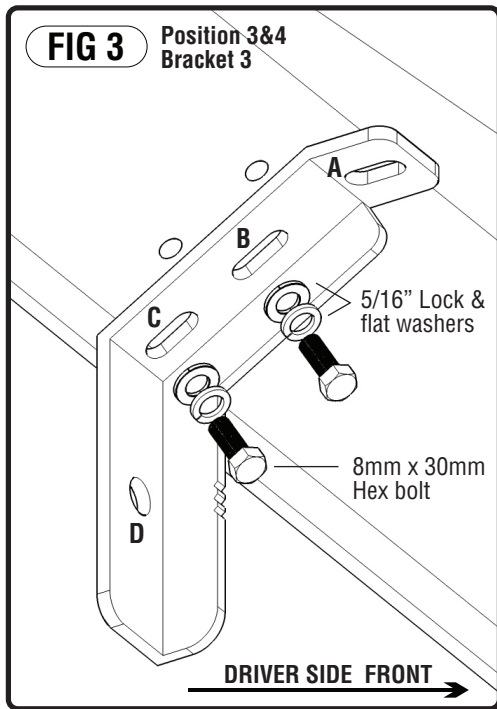

Bracket #3 (position 3&4)

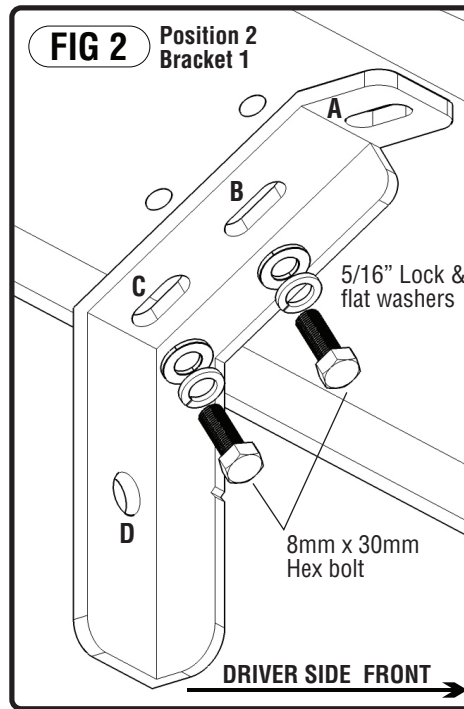

Bracket #1 (position 2)

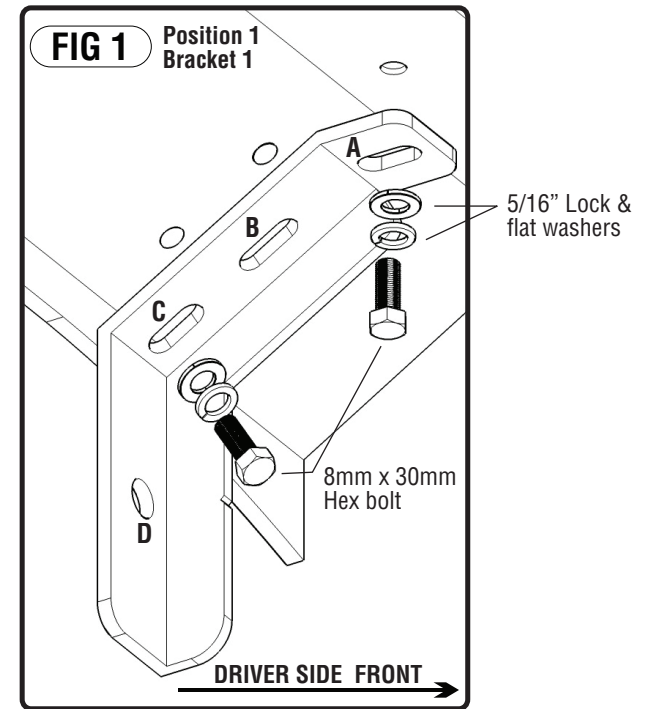

Bracket #1 (position 1)

When making final adjustments, we recommend tube to be placed 2-3 inches from the rear of the FRONT wheel well.

Rail should be centered to tube. (1" past inner hole of tube or 5" from tube ends).

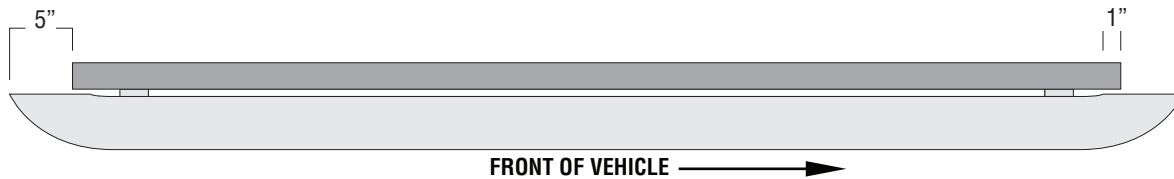

When making final adjustments to rail, make sure rail is not too far forward and touching the curved pinchweld. Rail should not go more than an 1.5" forward of front bracket.

