



92-510,520,522

99-10 GM Silverado/Sierra Reg, Ext, Crew Cab
04-09 1500 Crew Cab
01-09 HD Ext, Crew Cab

(866) 476-6276 / (866) IRONCROSS
www.ironcrossautomotive.com
IRON CROSS AUTOMOTIVE INC. 2009

ENDEAVOUR INSTALLATION SHEET

QTY.	PARTS LIST	QTY.	PARTS LIST
8	5/16 x 1 1/4" Hex Bolts	16	5/16 x 3/4" Hex Bolts
8	5/16 Flat Washers	24	5/16 Flange Nuts
16	1/4" Flat Washers	16	Self Tappers
8	Bracket Clamps	8	8mm Bolt
8	Brackets	8	8mm Nut Clips

FOLLOWING FOR KIT BUILDER USE ONLY - ADD: (4)x 8mm Bolts, (8) 8mm Nut Clips

07-10 MODELS USE PROVIDED 8mm NUT CLIPS.

Reg cabs use 4 clips at each body panel mount location. Ext cabs use 8 clips at each body panel mount location. Crew cabs only use 4 clips for the rear 2 mounting locations. FIG 3b

- STEP 1** Remove contents from box and check for damage parts. Verify all parts are present, making sure to read and understand instructions before beginning.
- STEP 2a Regular and Extended Cabs:** Measure using the "suggested" mounting locations (as in **FIG 1** on back of page), lay out and clearly mark the mounting locations for final bracket positions. Using a bracket as a template, mark the pinch weld hole locations and drill each hole. Some holes may have been drilled from factory. **FIG 2**
- STEP 3a Regular and Extended Cabs:** Position the main bracket and start the 5/16 bolt, washer through the pinch weld, then the lower slot in the bracket, followed by flange nut on the inside of the bracket. Now install two tek screws and 1/4" flat washer into the top holes of each bracket. **FIG 2**
-
- STEP 2b Crew Cab:** Locate factory running board mounts end of truck. You will use positions 1, 3, 5, 6. **FIG 1**
- STEP 3b Crew Cab:** Position the main bracket and start the 5/16 bolt, washer through the pinch weld, then the lower slot in the bracket, followed by flange nut on the inside of the bracket. Attach bracket in positions 1 and 3 with 8mm bolt and flat washer. **FIG 3**
- Position 5 and 6, install two tek screws in the top of the bracket. **FIG 3a**

MOUNTING BRACKET TO TRUCK

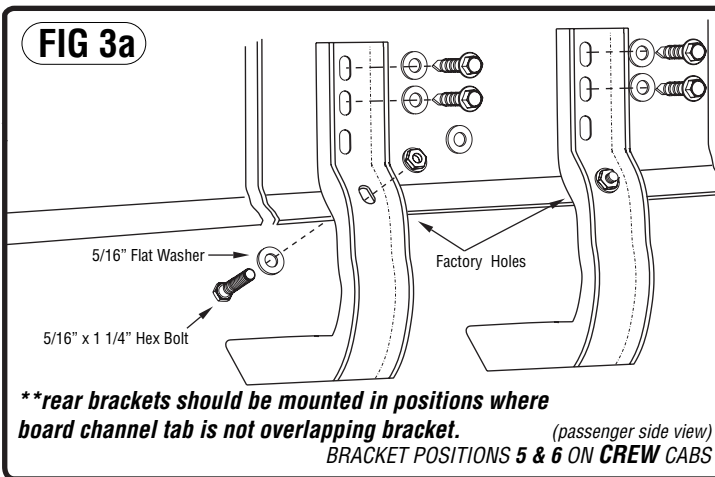
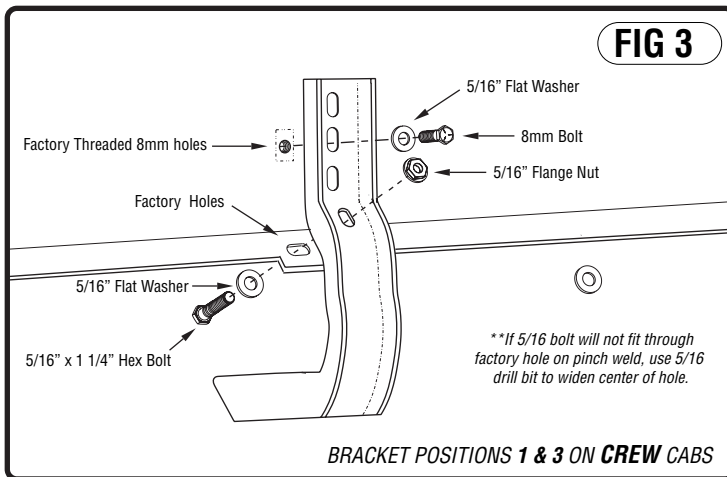
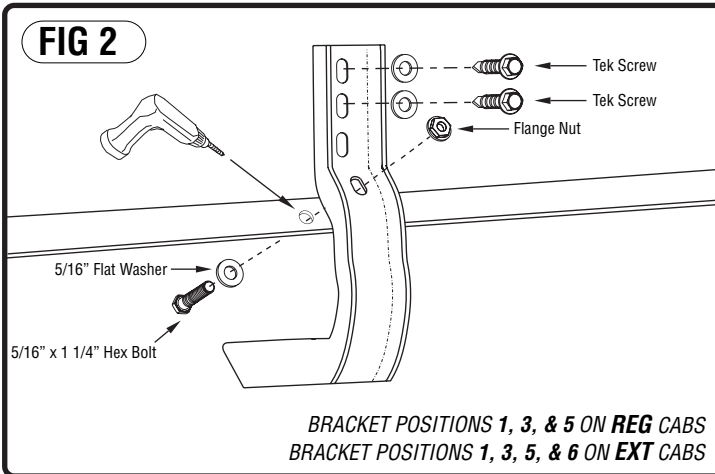
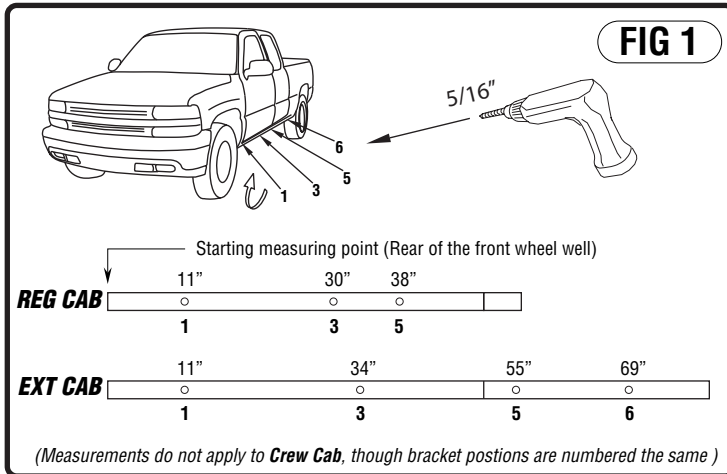

MOUNTING BOARD TO BRACKET

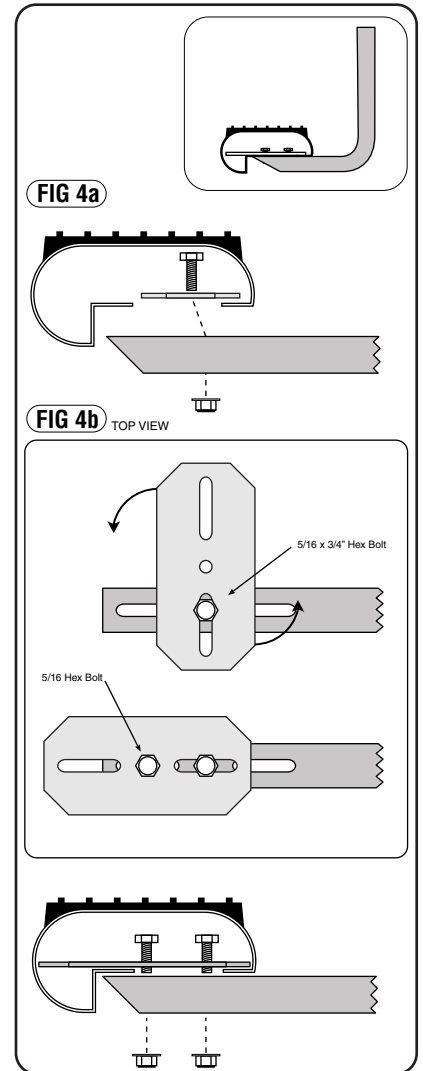

STEP 5

Mounting board to vehicle.

- 1) Place clamp brackets on main bracket, turn 90 degrees to the main brackets. Place 5/16" hex bolt through top of bracket clamp in oblong hole to center hole in main bracket, placing 5/16" flange nut on bottom side. Fig 4a
- 2) Place running board on main brackets, making sure that opening and the bottom of the board goes over the clamp brackets.
- 3) Rotate clamp brackets above main brackets, making sure that both edges of the running board are in between the clamp bracket and the main bracket. Install 5/16" hex bolt through center hole of bracket clamp and oblong hole of main bracket placing 5/16" flange nut on bottom side. Fig 4b
- 4) Adjust board to be centered under the cab of the vehicle and tighten the clamp brackets to the main brackets. Make sure all remaining hardware is tightened and test the running boards for attachments.

FIG 3b 07-09 MODELS ONLY

Remove rubber plugs and use 8mm nut clips when available.

