

04-10 Ford F-150 Reg, Super, Crew Cabs

(866) 476-6276 / (866) IRONCROSS

www.ironcrossautomotive.com

519 W. Dewey

Sapulpa, OK 74066

IRON CROSS AUTOMOTIVE INC. 2008

PARTS LIST

QTY	PARTS	QTY	PARTS
12	5/16" X 1.25" Hex Bolt	6	Brackets
12	5/16" Flange Bolt	6	Bracket Clamp
12	5/16" Flat Washer	12	5/16" Nut Clip
18	5/16" Flange Nut		

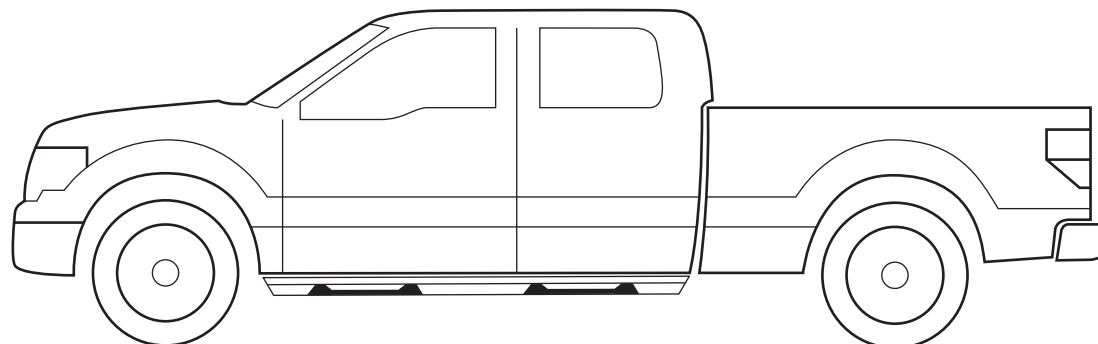
**BRACKET INSTALLATION**

- 1) Remove contents from box and check for damaged parts. Verify all parts are present, making sure to read and understand instructions before install.
- 2) Locate factory holes on inside body panel and pinchweld. **Fig 1** Regular Cabs have 2 mount locations, Super Cabs and Crew Cabs have 3.
- 3) Install nut clip into factory location. **Fig 2**
- 4) Position the bracket to the pinch weld holes. Install 5/6" hex bolt and 5/16" flat washer through pinch weld and holes "**B**" on bracket. Thread 5/16" flange nut onto hex bolt and tighten. **Fig 3**
- 5) Install 5/16" hex bolt, lock washer, and flat washer through holes "**A**" on bracket into nut clips and tighten. **Fig 3**
- 6) Repeat install on passenger side.

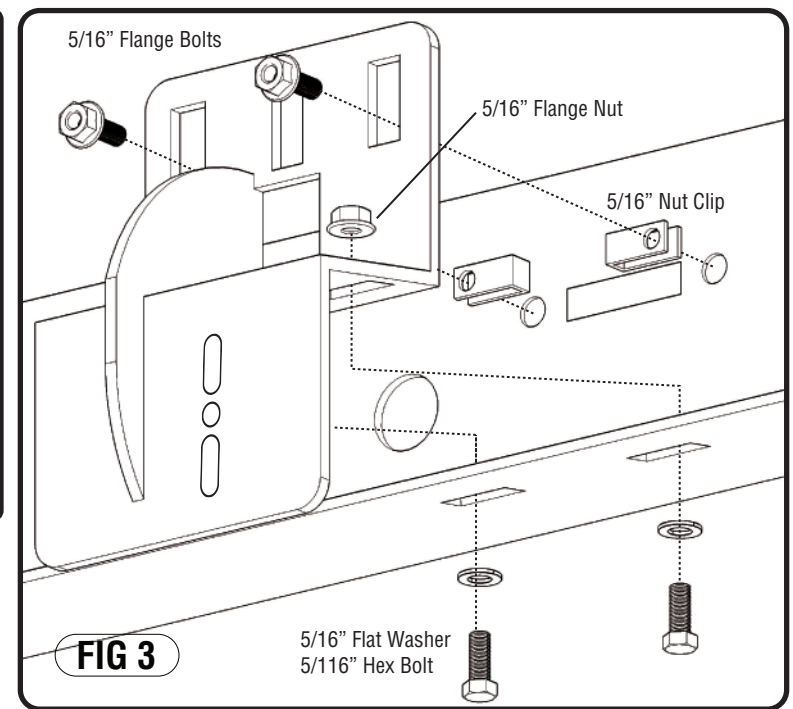
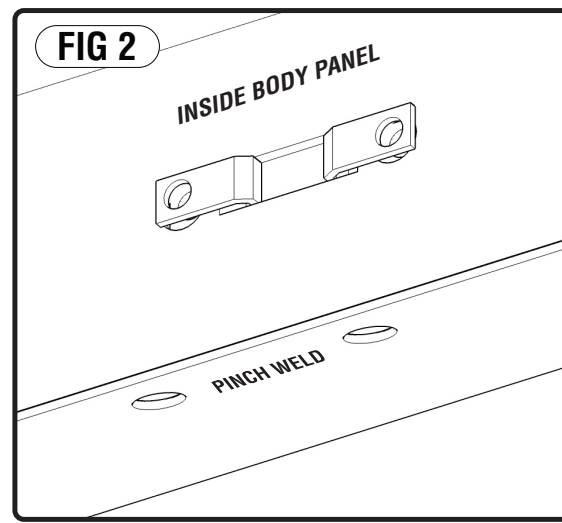
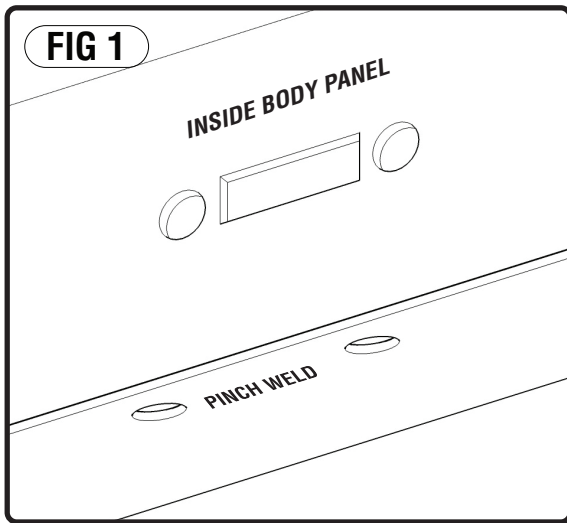

09 -F-150 MIDDLE BRACKET INSTALL: USE (1) NUT CLIP AND FLANGE BOLT FOR CENTER HOLE MOUNT

HD STEP INSTALL

1. Install 5/16" hardware and "bracket clamp" to each bracket through hole "C". Having a second person or jack stands will be helpfull on install.
2. CAREFULLY place HD STEP over bracket clamps and align so that clamp tabs are in between step channel. Begin to hand tighten 5/16" flange nuts while making sure bracket clamp tabs are aligning to the bracket holes.
3. Once you have all clamps hand tightned to brackets, this should allow the HD STEP to slide forward and back to allow for final alignment to vehicle.
4. Once satisfied with alignment, tighten all 5/16" flange nuts for final install.

