

PARTS LIST

QTY	PART	QTY	PART
4	BRACKET # 1	18	5/16" LOCK WASHER
4	BRACKET # 2	8	5/16" CARRIAGE BOLT
16	8mm HEX BOLT	8	5/16" FLANGE NUT
16	5/16" FLAT WASHER	8	BRACKET CLAMP

Remove contents from box and check for damage parts. Verify all parts are present, making sure to read and understand instructions before beginning.

Brackets #1 Installation (positions 1&2)

- 1) Distinguish driver and passenger side brackets. The brackets with a 90 degree side brace should be facing the front of the vehicle.
- 2) Bracket #1 will have (1) notch on side brace.
- 3) Align the #1 brackets at positions 1 & 2 to the 8mm threaded factory sidewall holes and install 8mm flat washers, lock washers and hex bolts. (Position 1 will use holes "A" & "C". Position 2 will use holes "B" and "C").
- 4) Tighten brackets at this time.

Brackets #2 Installation (positions 3&4)

- 5) Bracket #2 will have (2) notches on the side brace.
- 6) Align the #2 brackets at positions 3 & 4 to the 8mm threaded factory sidewall holes "B" & "C" and install 8mm flat washer, lock washer and hex bolt.
- 7) Tighten brackets at this time.

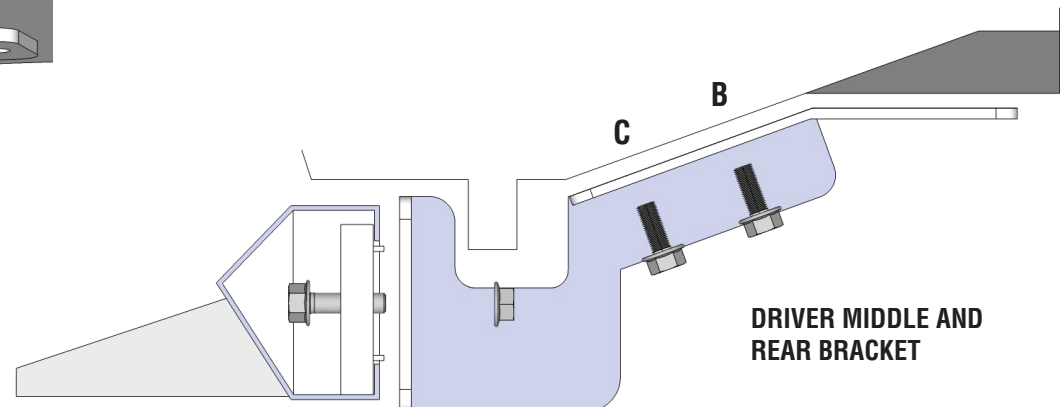
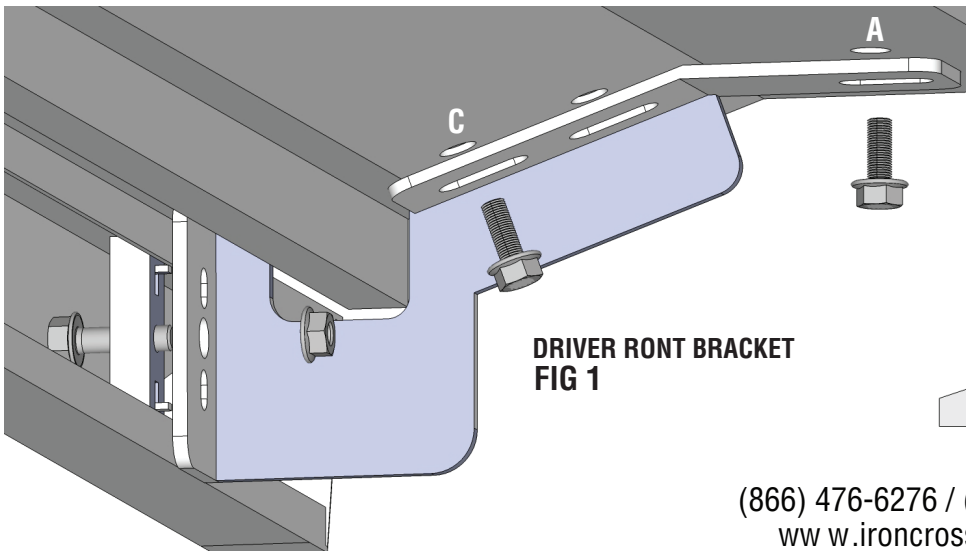

07-10 Tundra Double Cab
07-10 Tundra CrewMax

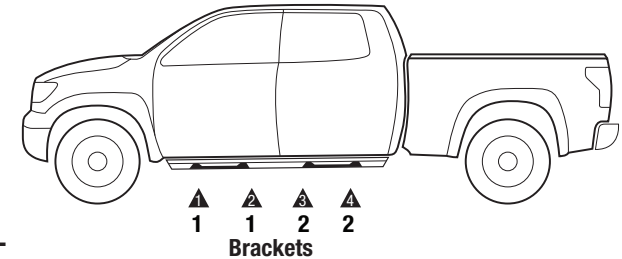

HD STEP INSTALL

1. Install 5/16" carriage bolt and "bracket clamp" to each bracket through hole (fig1). Having a second person or jack stands will be helpful on install.
2. CAREFULLY place HD STEP over bracket clamps and align so that clamp tabs are in between step channel. Begin to hand tighten 5/16" flange nuts while making sure bracket clamp tabs are aligning to the bracket holes.
3. Once you have all clamps hand tightened to brackets, this should allow the HD STEP to slide forward and back to allow for final alignment to vehicle.
4. Once satisfied with alignment, tighten all 5/16" flange nuts for final install.